

SECTION Z-Z

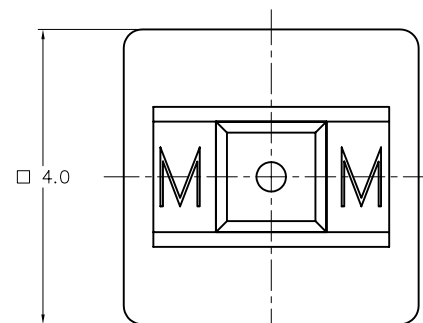

VIEW "Y"

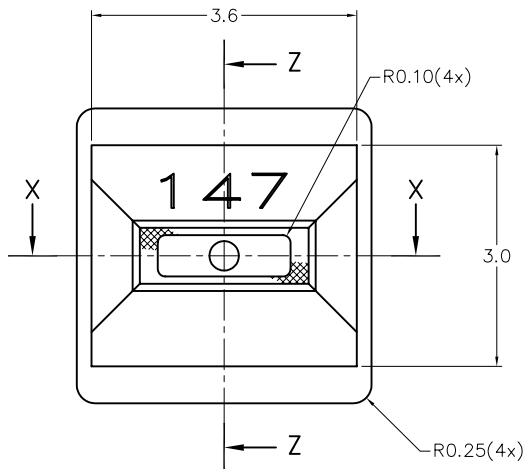
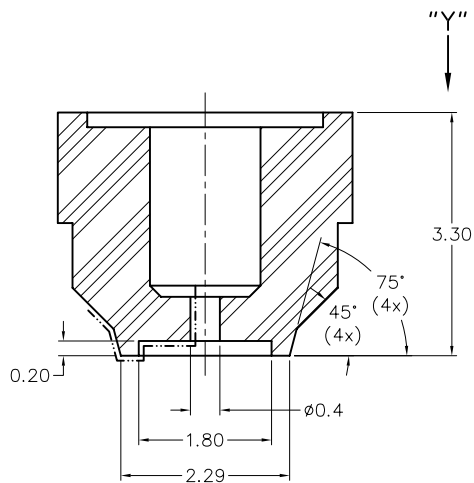

SECTION X-X

- NOTE :
- FLASHFREE AREA, NO VOIDS AND FOREIGN PARTICALS
 - ALL CORNER WITH RADIUS 0.10 MM MAXIMUM

**SALES COPY
UNCONTROLLED DOCUMENT**

Copying of this document and giving it to others and the use of communication of the contents thereof are forbidden without express authority. Offenders are liable to the payment of damages. All rights are reserved in the event of the grant of a patent or the registration of a utility model or design.

TOLERANCE UNLESS SPECIFIED X.X ±0.10 GENERAL TOL. ±0.2 X.XX ±0.05 ANGLE ±0.5° SURFACE FINISH 1.6/√ REMOVE BURRS AND SHARP EDGES ALL DIMENSIONS IN MM. <small>13-99-027 R03</small>	MATERIAL: NBR	PROCESS: —	TITLE: RUBBER TIP (12U3 HOLDER) (MOLD #308-2083)	REV. 2	
	 MICRO-MECHANICS PTE LTD mmsingapore@micro-mechanics.com TEL: 67468800 FAX: 67467700	DATE: 29-4-09	DRAFTSMAN: HT LEK	SCALE: 15:1	SHEET 1
		CHECKER: MT HAN	DRAWING NO: R3-147		1